

140 / 150 / 160 W Polycrystalline Solar Module



Warranty
 10-year repair and workmanship warranty
 12-year warranty at 90% power output
 25-year warranty at 80% power output

Typical Electrical Characteristics

Models	NHN- 140W-PS	NHN- 150W-PS	NHN- 160W-PS
Max. Power (Pmax)	140Wp	150Wp	160Wp
Optimum Operating Voltage (Vm)	17.2V	17.8V	18.2V
Optimum Operating Current (Im)	8.14A	8.43A	8.79A
Open-circuit Voltage (Voc)	21.8V	22.4V	22.8V
Short-circuit Current (Isc)	8.62A	8.93A	9.28A
Module efficiency	14.1%	15.2%	16.1%

Note: Note: the specifications are obtained under the Standard Test Condition (STC): 1,000W/m², Am 1.5, Cell Temperature 25°C

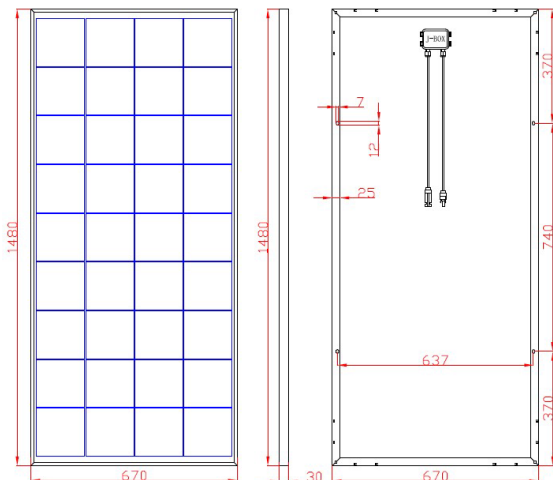

Solar cell	Poly-crystalline 156×156mm
Power Tolerance (Pmax)	0 ~ +3%
Numbers of cells	36pcs of cells in series
Module Dimension	1480×670×30mm
Weight	10Kg
Max. System Voltage	1000V DC
Max. Series Fuse Rating	—
Temperature cycling range	-40°C ~ +85°C
NOTC	47°C
Temperature coefficients of Isc	(+0.06%/°C)
Temperature coefficients of Voc	(-0.35%/°C)
Temperature coefficients of Pmax	(-0.4%/°C)
Load Capacity	392pcs/ 20'GP 840pcs/ 40'GP

140 / 150 / 160 W Polycrystalline Solar Module

Functional Features

- Applies to commercial, residential applications for off-grid applications.
- Produced with strict quality control standards and a worldwide certification program.
- Easily installed on the ground, roof, building face or tracking system.
- Reduces electricity cost and creates energy independently.
- Modular, no moving parts, fully scalable and easily installed.
- Reliable and virtually maintenance-free power generation.
- Helps environment by reducing air, water and land pollution.
- Provides clean, quiet and reliable electricity generation.

I-V CURVE

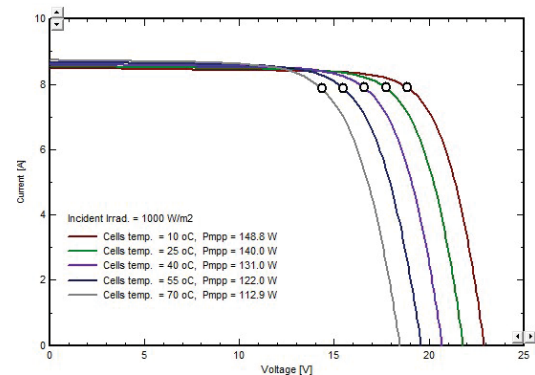
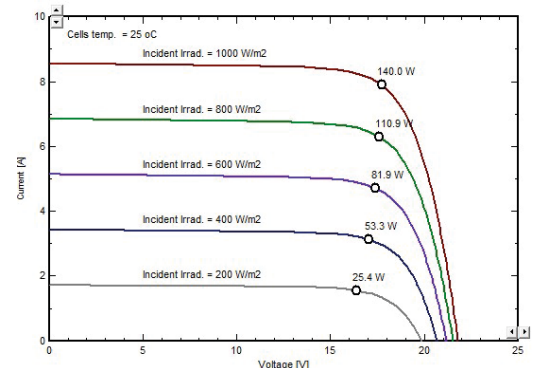

Certification

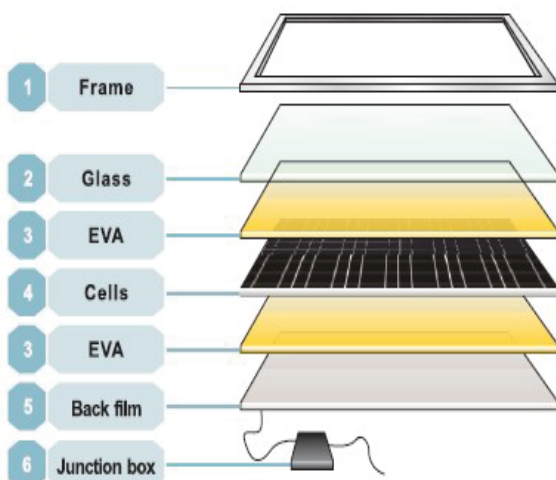

The Structure of Solar Modules

Cells

The hi-efficiency of mono and poly solar cells ensure adequate power for panels.

Glass

Low-iron tempered glass, 3.2mm thickness with higher reflectivity.

EVA

Higher transmission rate, antioxidant capacity and temperature resistance, no expansion or contraction.

Back film

Increase efficiency of modules slightly and reduce module's temperature. Aging resistance, corrosion resistance and airtight.

Aluminum Frame

Using the framework of the anodized aluminum frame with high intensity, mechanical shock resistance capacity.